

01-85 SERIES

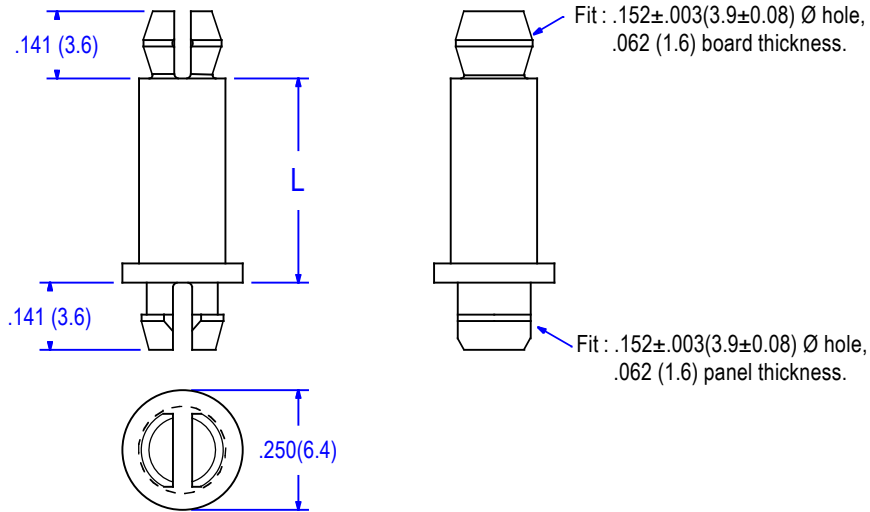

ITEM NO.	L	
	In. $\pm .015$	mm. ± 0.4
01-85-20	.125	3.2
01-85-30	.187	4.8
01-85-40	.250	6.4
01-85-50	.312	7.9
01-85-60	.375	9.5
01-85-70	.437	11.1
01-85-80	.500	12.7
01-85-100	.625	15.9
01-85-110	.689	17.5
01-85-120	.750	19.1
01-85-140	.875	22.2
01-85-160	1.00	25.4
01-85-200	1.25	31.8
01-85-220	1.38	34.9

Packaging : 1000 pcs. per bag

MATERIAL	NYLON 66
UL RATING	94V-2
UL FILE NO.	E41938
COLOR	NATURAL
RoHS COMPLIANCE	YES
TEMPERATURE RANGE (REF.)	-40 to 185°F (-40 to 85°C)
MR NUMBER	12

				BY	DATE	Title	
						PCB SUPPORT, MINIATURE	
						Part No.	Issue
						01-85 SERIES	A
				DIMENSIONS Inches (mm) Tolerance .xx = $\pm .010$.xxx = $\pm .005$		Drwg. type	10-20-18
A	.Added item No 01-85-110	10-20-18	FL	ALL ELECTRONICS HARDWARE INC. 2642 Corporate Parkway Algonquin, IL. 60102 1-800-778-7234		CATALOG	
No	Revision	Date	Init.			File No.	01-85 series